



HEALTH CONNECT PARTNERS

HOSPITAL PHARMACY

CONFERENCE | **SPRING 15**



CardinalHealth

Essential to care™

What makes someone a healthcare expert?

Take a brilliant mind and add education, experience and a passion for patient care.



**Natasha Nicol,
PharmD, FASHP**

Ask me about

Patient safety; Just Culture; preventing medication errors using technology; Disclosure; pharmacy consultative services



**Patricia Kienle,
RPh, MBA,
FASHP**

Ask me about

Joint Commission accreditation; medication administration; medication safety; compounding; accountability measures



**Brad Tice,
PharmD, MBA,
FAPhA**

Ask me about

Medication Therapy Management; population health management; pharmacy clinical services; outcomes measurement; quality measurement



**Mary Baxter,
MBA, RPh**

Ask me about

Leveraging the hospital pharmacy as a strategic asset; population health management; healthcare strategy; hospital operations

Meet our Experts 
on *Essential Insights*
[cardinalhealth.com/
HCPExperts](http://cardinalhealth.com/HCPExperts)



We are happy to have you with us at our 2015 Spring Hospital Pharmacy Conference here in sunny Orlando, FL! This conference is a perfect platform to network and connect, develop business relationships, be inspired by thought-provoking education, and discover new technology products. Special thanks to Cardinal, our title sponsor, for their continued support of this unparalleled event.



Over the next few days, our conference will provide you with numerous networking opportunities as well as educational sessions with topics including “Hazardous Drugs,” “Control Substance Drug Diversion,” and “Biosimilars - Implications for Hospitals and Health Systems.” We are also proud to present Dr. Jason Selk as our keynote speaker for a powerful session entitled “Relentless Solution Focus: The Ultimate Measure of Mental Toughness”.

As always, this conference features two Reverse EXPO sessions (Tuesday afternoon & Wednesday morning), sponsored by Cantrell Drug Company, where the Hospital Pharmacy Directors host the booths while the suppliers walk through the expo hall. Don't miss the Supplier Showcase, open on Monday only from 12:00 noon – 4:00 pm in Oceans Ballroom. Stop by to check it out, and if you are interested in having a showcase of your own at the next conference, visit the HCP table in the expo hall to let us know.

If you need assistance at any time, our staff at the registration desk are happy to help.

Sincerely,

Jason Green
Chief Sales Officer

Title Sponsor



HEALTH CONNECT PARTNERS



Jason Green holds the post of Chief Sales Officer for Health Connect Partners. He has extensive experience in the healthcare industry, working in both large corporate environments and small start-up healthcare organizations. Jason's ability to relate to customers and colleagues has allowed him to foster many long-term relationships throughout the healthcare industry. He loves spending time with customers and engaging about their business, families and ways he can be helpful.

Jason and his wife Dana have two children, Max (11) and Ella Kate (5), who keep him dedicated to a busy social calendar. Ella Kate is involved with dance, gymnastics, cheerleading and ballet. She loves dressing up and raiding the closet for mom's newest outfits, shoes and hats. Max has kicked off his 2015 golf tour with his first tournament at Innisbrook Golf Club just outside of Tampa, FL. He will continue to advance through to many tournaments in many exciting golf resorts in NC, FL, GA and VA. When not studying, he can be found with his clubs and fishing pole heading to the course or tormenting the local alligator in a nearby pond.

During the break in activity, Jason enjoys playing golf, fishing, snow skiing and anything that involves water. This past year he found a new passion for fly fishing as he spent 10 days fishing in the beautiful rivers of the North Carolina Mountains. He is actively involved in his community, serving on several charitable volunteer boards. Jason is a graduate of Ohio University. He continues to cheer for the Pittsburgh Steelers, Boston Red Sox, Ohio State Buckeyes and most recently made the switch to the SEC South Carolina Gamecocks.



JASON GREEN
Chief Sales Officer
Hilton Head, SC

David Mason is Co-Founder and CEO of Health Connect Partners. Prior to founding HCP, he was Founder and President of BCX Technology, Inc., a software automation company specializing in supply automation for acute care hospitals. He led the BCX team for eight years and sold the company in 2003 to Omnicell.

David and his wife Tammy have two wonderful children, Alexis (21) and Madison (14). Alexis is married to Zac Morgan and they live in Johnson City, TN, where they both attend physical therapy school at East Tennessee State University. Madison stays busy with music lessons and is very good at piano. An avid boater, David spends his time boating with his family, fishing, diving, lobster hunting, spear fishing, running, swimming and mountain bike riding. David enjoys Corvettes and participates in autocross events in his 2007 Corvette with his local Corvette club. David is a graduate of Nashville State Technical Institute, Chairman of the Board for BCX Foundation (a nonprofit educational foundation for children), a Black Belt in Wado Ryu Karate and an Eagle Scout.



DAVID MASON
Chief Executive Officer
Lebanon, TN

Nelson Hendry, Co-Founder and President, oversees the Providers registration and participation at all HCP Conferences. Prior to founding HCP, he served as Regional Vice President of Corporate Sales for Omnicell, working with large IDN Health Systems and the major GPOs. He was awarded the 2005 Salesman of the Year Award for Omnicell's Specialty Sales. Nelson graduated with a Bachelor of Science degree from Florida State University.

Nelson and his wife Evelyn have three boys. Joseph (26) is a 3D video game artist at Pocket Gems in San Francisco, and enjoys weight lifting in his spare time. Justin (24) is a recent M.I.T. Graduate with a degree in Mechanical Engineering and is now an equity stock trader at Kershner Trading Group in Austin, TX. Taylor (12) is in 6th grade at Berkeley Prep School in Tampa and is a soccer player, fantasy and flag football enthusiast, and loves to do any kind of fishing.



NELSON HENDRY
President
Palm Harbor, FL



Kcentra

**WHEN PATIENTS
NEED URGENT
WARFARIN
REVERSAL...**

**EVERY
MOMENT
COUNTS**

Kcentra—the First and Only 4-Factor Prothrombin Complex Concentrate (4F-PCC) for Urgent Warfarin Reversal

Important Safety Information

Kcentra is a blood coagulation factor replacement product indicated for the urgent reversal of acquired coagulation factor deficiency induced by Vitamin K antagonist (VKA—eg, warfarin) therapy in adult patients with acute major bleeding or the need for urgent surgery or other invasive procedure. Kcentra is for intravenous use only.

WARNING: ARTERIAL AND VENOUS THROMBOEMBOLIC COMPLICATIONS

Patients being treated with Vitamin K antagonist therapy have underlying disease states that predispose them to thromboembolic events. Potential benefits of reversing VKA should be weighed against the risk of thromboembolic events, especially in patients with history of such events. Resumption of anticoagulation therapy should be carefully considered once the risk of thromboembolic events outweighs the risk of acute bleeding. Both fatal and nonfatal arterial and venous thromboembolic complications have been reported in clinical trials and postmarketing surveillance. Monitor patients receiving Kcentra, and inform them of signs and symptoms of thromboembolic events. Kcentra was not studied in subjects who had a thromboembolic event, myocardial infarction, disseminated intravascular coagulation, cerebral vascular accident, transient ischemic attack, unstable angina pectoris, or severe peripheral vascular disease within the prior 3 months. Kcentra might not be suitable for patients with thromboembolic events in the prior 3 months.

Kcentra is contraindicated in patients with known anaphylactic or severe systemic reactions to Kcentra or any of its components (including heparin, Factors II, VII, IX, X, Proteins C and S, Antithrombin III and human albumin). Kcentra is also contraindicated in patients with disseminated intravascular coagulation. Because Kcentra contains heparin, it is contraindicated in patients with heparin-induced thrombocytopenia (HIT). Hypersensitivity reactions to Kcentra may occur. If patient experiences severe allergic or anaphylactic type reactions, discontinue administration and institute appropriate treatment.

In clinical trials, the most frequent (≥2.8%) adverse reactions observed in subjects receiving Kcentra were headache, nausea/vomiting, hypotension, and anemia. The most serious adverse reactions were thromboembolic events, including stroke, pulmonary embolism and deep vein thrombosis.

Kcentra is derived from human plasma. The risk of transmission of infectious agents, including viruses and, theoretically, the Creutzfeldt-Jakob disease (CJD) agent, cannot be completely eliminated.

The safety and efficacy of Kcentra in pediatric use have not been studied, and Kcentra should be used in women who are pregnant or nursing only if clearly needed.

Please see brief summary of full prescribing information on reverse.

Kcentra—Ready When You Need It

- The first and only non-activated 4F-PCC for urgent warfarin reversal in adult patients with:
 - Acute major bleeding or
 - Need for an urgent surgery/invasive procedure
- Mean infusion time ~7x faster than plasma
- Room temperature storage for 36 months

Kcentra has over 15 years of clinical experience as Beriplex® outside the US.

www.Kcentra.com

**Kcentra Hotline: 1-855-4KCENTRA
(1-855-452-3687)**

Kcentra®
Prothrombin Complex Concentrate (Human)

Urgent Warfarin Reversal

**KCENTRA® (Prothrombin Complex Concentrate [Human])
For Intravenous Use, Lyophilized Powder for Reconstitution
Initial U.S. Approval: 2013**

BRIEF SUMMARY OF PRESCRIBING INFORMATION

These highlights do not include all the information needed to use Kcentra safely and effectively. See full prescribing information for Kcentra.

WARNING: ARTERIAL AND VENOUS THROMBOEMBOLIC COMPLICATIONS
Patients being treated with Vitamin K antagonists (VKA) therapy have underlying disease states that predispose them to thromboembolic events. Potential benefits of reversing VKA should be weighed against the potential risks of thromboembolic events, especially in patients with the history of a thromboembolic event. Resumption of anticoagulation should be carefully considered as soon as the risk of thromboembolic events outweighs the risk of acute bleeding.

- Both fatal and non-fatal arterial and venous thromboembolic complications have been reported with Kcentra in clinical trials and post marketing surveillance. Monitor patients receiving Kcentra for signs and symptoms of thromboembolic events.
- Kcentra was not studied in subjects who had a thromboembolic event, myocardial infarction, disseminated intravascular coagulation, cerebral vascular accident, transient ischemic attack, unstable angina pectoris, or severe peripheral vascular disease within the prior 3 months. Kcentra may not be suitable in patients with thromboembolic events in the prior 3 months.

-----INDICATIONS AND USAGE-----

Kcentra, Prothrombin Complex Concentrate (Human), is a blood coagulation factor replacement product indicated for the urgent reversal of acquired coagulation factor deficiency induced by Vitamin K antagonist (VKA, e.g., warfarin) therapy in adult patients with:

- acute major bleeding or
- need for an urgent surgery/invasive procedure.

-----DOSAGE AND ADMINISTRATION-----

For intravenous use only

- Kcentra dosing should be individualized based on the patient's baseline International Normalized Ratio (INR) value, and body weight.
- Administer Vitamin K concurrently to patients receiving Kcentra to maintain factor levels once the effects of Kcentra have diminished.
- The safety and effectiveness of repeat dosing have not been established and it is not recommended.
- Administer reconstituted Kcentra at a rate of 0.12 mL/kg/min (~3 units/kg/min) up to a maximum rate of 8.4 mL/min (~210 units/min.).

Pre-treatment INR	2 – < 4	4 – 6	> 6
Dose* of Kcentra (units [†] of Factor IX) / kg body weight	25	35	50
Maximum dose [‡] (units of Factor IX)	Not to exceed 2500	Not to exceed 3500	Not to exceed 5000

* Dosing is based on body weight. Dose based on actual potency as stated on the carton, which will vary from 20-31 Factor IX units/mL after reconstitution. Nominal potency is 500 or 1000 units per vial, approximately 25 units per mL after reconstitution.

† Units refer to International Units.

‡ Dose is based on body weight up to but not exceeding 100 kg. For patients weighing more than 100 kg, maximum dose should not be exceeded.

-----DOSAGE FORMS AND STRENGTHS-----

- Kcentra is available as a single-use vial containing coagulation Factors II, VII, IX and X, and antithrombotic Proteins C and S as a lyophilized concentrate.

-----CONTRAINDICATIONS-----

Kcentra is contraindicated in patients with:

- Known anaphylactic or severe systemic reactions to Kcentra or any components in Kcentra including heparin, Factors II, VII, IX, X, Proteins C and S, Antithrombin III and human albumin.
- Disseminated intravascular coagulation.
- Known heparin-induced thrombocytopenia. Kcentra contains heparin.

-----WARNINGS AND PRECAUTIONS-----

- Hypersensitivity reactions may occur. If necessary, discontinue administration and institute appropriate treatment.
- Arterial and venous thromboembolic complications have been reported in patients receiving Kcentra. Monitor patients receiving Kcentra for signs and symptoms of thromboembolic events. Kcentra was not studied in subjects who had a thrombotic or thromboembolic (TE) event within the prior 3 months. Kcentra may not be suitable in patients with thromboembolic events in the prior 3 months.
- Kcentra is made from human blood and may carry a risk of transmitting infectious agents, e.g., viruses, the variant Creutzfeldt-Jakob disease (vCJD) agent, and theoretically, the Creutzfeldt-Jakob disease (CJD) agent.

-----ADVERSE REACTIONS-----

- The most common adverse reactions (ARs) (frequency ≥2.8%) observed in subjects receiving Kcentra were headache, nausea/vomiting, hypotension, and anemia.
- The most serious ARs were thromboembolic events including stroke, pulmonary embolism, and deep vein thrombosis.

To report SUSPECTED ADVERSE REACTIONS, contact CSL Behring at 1-866-915-6958 or FDA at 1-800-FDA-1088 or www.fda.gov/medwatch.

-----USE IN SPECIFIC POPULATIONS-----

Pregnancy: No human or animal data. Use only if clearly needed.

Based on March 2014R version.

AGENDA AT A GLANCE



MONDAY MAY 4

11:30 am - 4:00 pm:	Provider Registration	Oceans Ballroom
11:30 am - 7:30 pm:	Supplier Registration	Crystal Registration Desk
12:00 pm - 4:00 pm:	Supplier Showcase	Oceans Ballroom
4:15 pm - 5:30 pm:	Provider Orientation	Crystal Ballroom
5:30 pm - 6:15 pm:	Provider Dinner	Discovery Ballroom
6:00 pm - 6:30 pm:	Supplier Orientation	Crystal Ballroom
6:30 pm - 7:30 pm:	Welcome Reception	Terrace Lawn
7:30 pm -	Hospitality Suites	Second Floor

TUESDAY MAY 5

7:00 am - 6:00 pm:	Registration Desk Open	Crystal Registration Desk
7:00 am - 8:00 am:	Breakfast	Discovery Ballroom
8:00 am - 9:30 am:	Opening Remarks & Keynote Address	Crystal Ballroom
9:30 am - 9:45 am:	Coffee Break	Crystal Prefunction
9:45 am - 10:45 am:	Educational Session	Crystal Ballroom
11:00 am - 12:00 pm:	Educational Session	Crystal Ballroom
11:30 am - 1:00 pm:	Lunch	Terrace Lawn
1:15 pm - 2:30 pm:	Educational Session	Crystal Ballroom
3:00 pm - 5:00 pm:	Reverse EXPO Session 1	Oceans Ballroom
6:00 pm - 10:00 pm:	Dinner & Entertainment	SeaWorld's Ports of Call

**Shuttles will run continuously between the hotel and Ports of Call from 5:50 pm - 10:00 pm.*

WEDNESDAY MAY 6

7:00 am - 12:00 pm:	Registration Desk Open	Crystal Registration Desk
7:00 am - 8:00 am:	Breakfast	Discovery Ballroom
8:00 am - 9:00 am:	Educational Session	Crystal Ballroom
9:30 am - 11:30 am:	Reverse EXPO Session 2	Oceans Ballroom





SECOND FLOOR

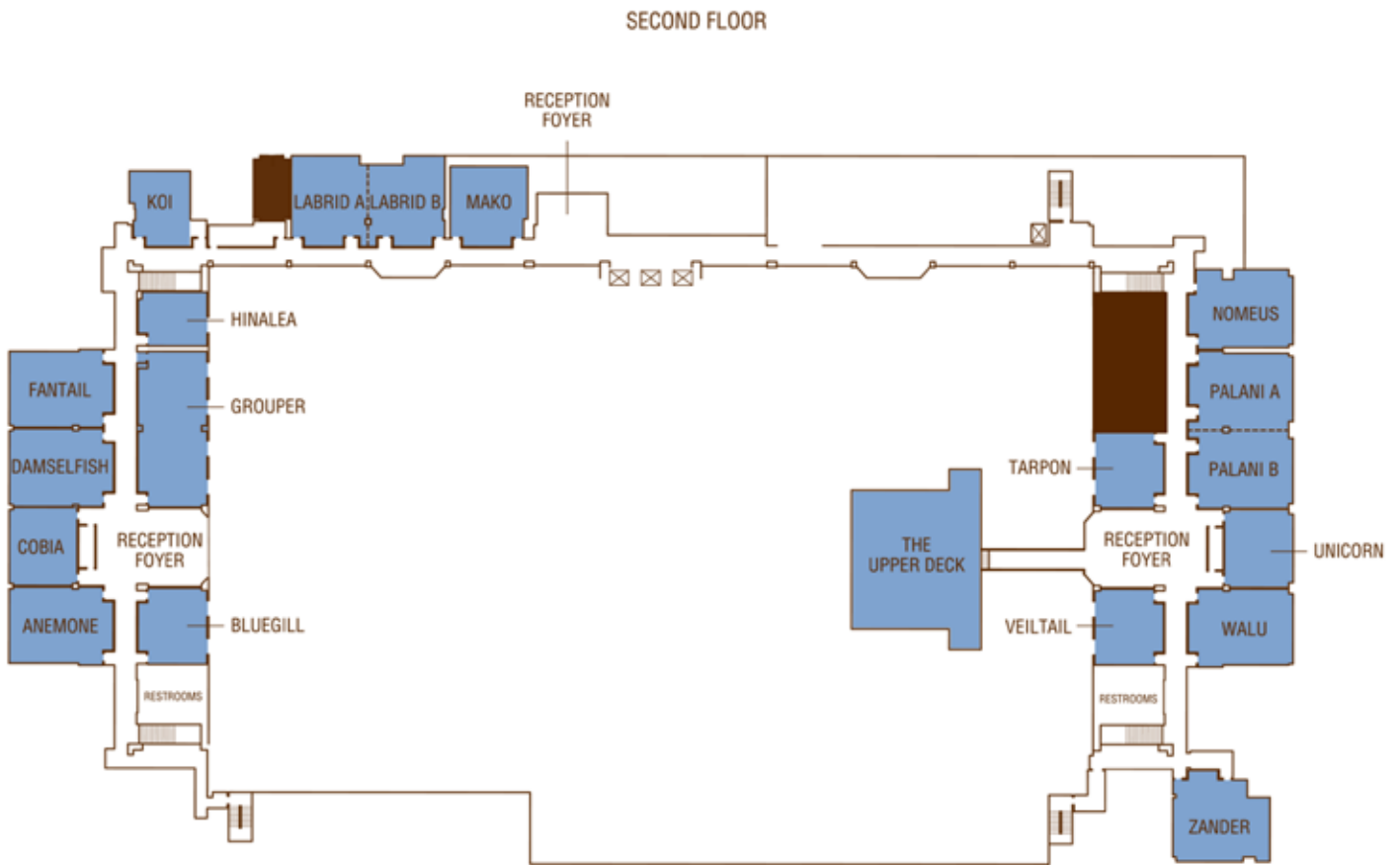

SPECIAL THANKS TO OUR SPONSORS



CardinalHealth

Essential to care™



Biotherapies for Life® **CSL Behring**



For information on future sponsorship opportunities, please visit Jason Green at the HCP booth in the expo hall.



HEALTH CONNECT PARTNERS

HOSPITAL PHARMACY CONFERENCE

FALL 15

October 12 - 14
Los Angeles, CA



TAKE ADVANTAGE OF OUR SPECIAL ONSITE PRICING
REGISTER TODAY: \$1,695 / EACH

UNTIL 12 NOON, WEDNESDAY 5/6



OCEANS BALLROOM

MONDAY, MAY 4TH • 12:00 pm - 4:00 pm

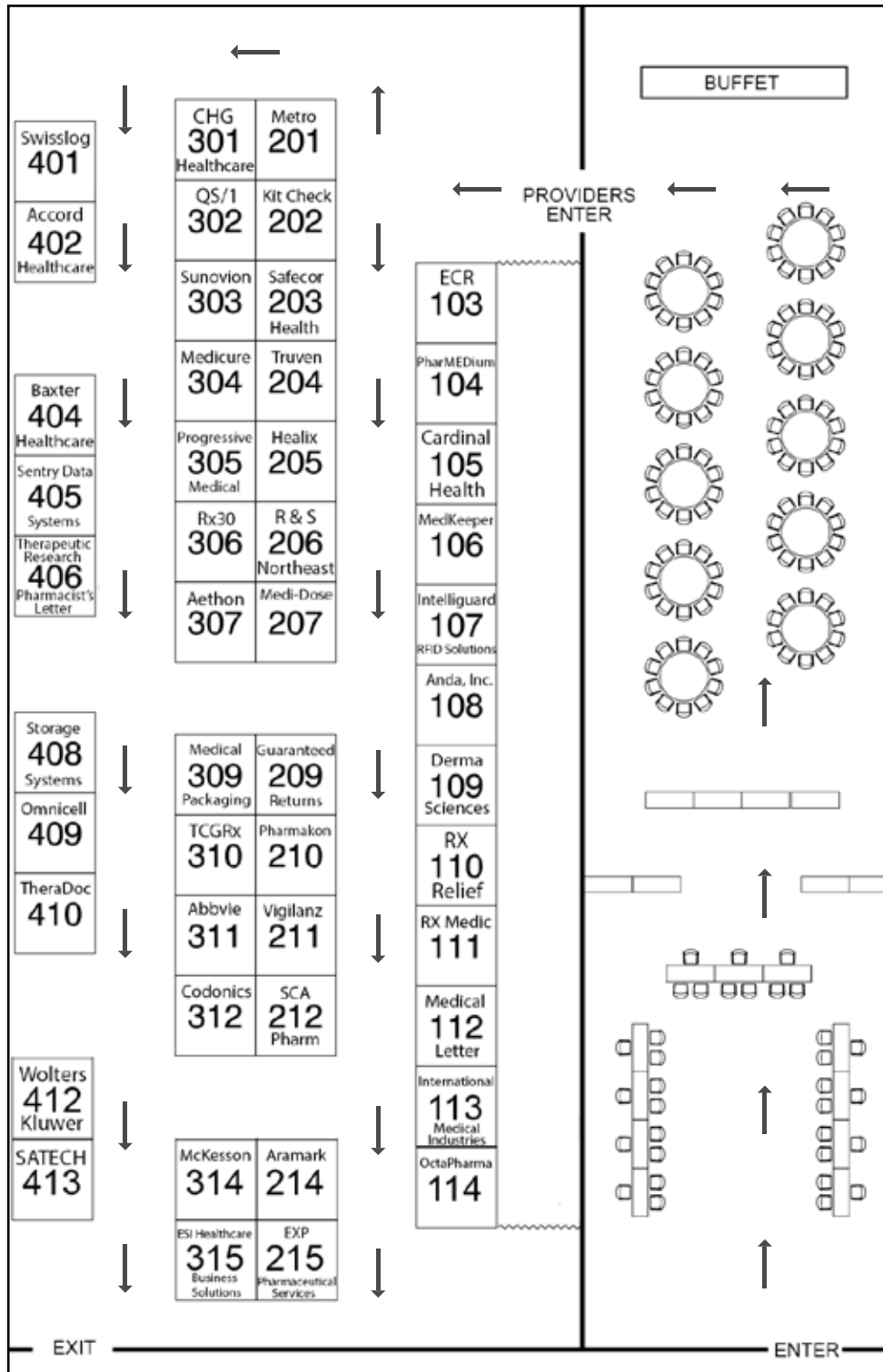

SPECIAL THANKS TO OUR 2015
PREMIUM SPONSOR





HEALTH CONNECT PARTNERS



SHARE YOUR PRODUCTS, SERVICES & TECHNOLOGY BEFORE THE REVERSE EXPO



HEALTH CONNECT PARTNERS

HOSPITAL PHARMACY

CONFERENCE | FALL 15

October 12 - 14 • Los Angeles, CA

We have a limited number of 10'x10' showcases available from 12:00 pm - 4:00 pm on the first day of the conference to showcase your company.

Supplier Showcase Pricing **\$3,000 per booth package**

Does not include attendees

* Premium and corner spaces, add an additional \$250

For more information about this exciting opportunity, contact:
Jason Green at Jason.Green@HLTHCP.com - (843) 689-9996

EXPAND YOUR PRESENCE

Monday, October 12th • 12:00 noon - 4:00 pm



HEALTH CONNECT PARTNERS

HOSPITAL PHARMACY

CONFERENCE | FALL 15

October 12 - 14 • Los Angeles, CA

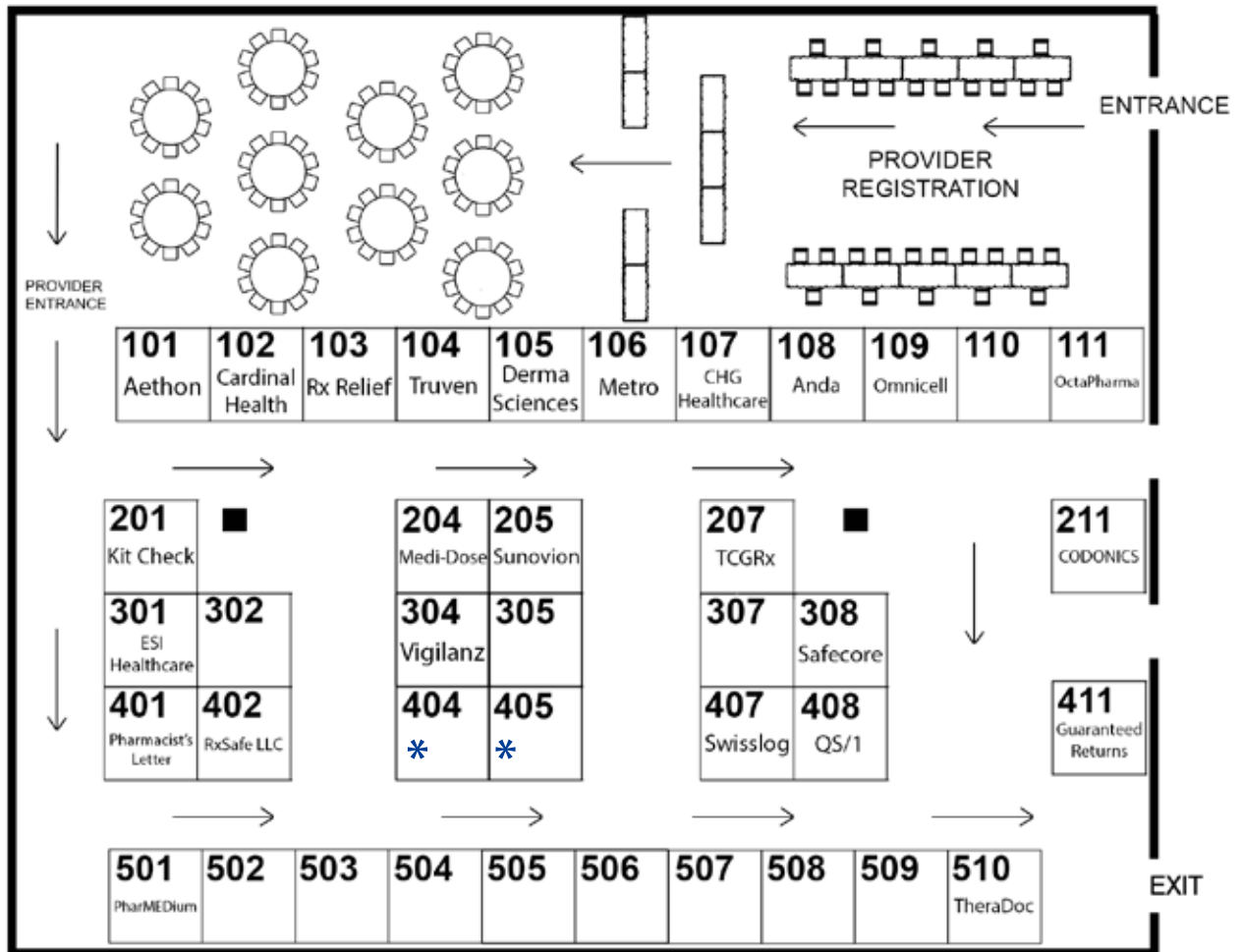

For more information about this exciting opportunity, contact:
Jason Green at Jason.Green@HLTHCP.com - (843) 689-9996



DON'T MISS THE HOSPITALITY SUITES

Monday Night

following our Welcome Reception from 7:30 PM - . . .



CardinalHealth

Essential to care™

BE SURE TO VISIT THE TITLE SPONSOR'S SUITE ON THE FIRST FLOOR FLOOR • R KITCHEN

PROVIDERS:

Don't forget your badge – you will need it to enter the hospitality suites. Start your evening in the suite that matches the logo on the back of your badge. If you are scanned into 15 of the hospitality suites, you will be entered in a drawing for an autographed guitar.

HOSPITALITY SUITES



MONDAY, MAY 4TH • 7:30 pm - ...

SPONSOR	LEVEL	ROOM
Cardinal	First Floor	R Kitchen
Aethon	Second Floor	Damselfish
AMAG	Second Floor	Koi
AmerisourceBergen Corporation	Second Floor	Tarpon
BD Medical	First Floor	Odyssey B
Carefusion	First Floor	Odyssey A
Cantrell Drug Company	Second Floor	Walu
CSL Behring	Second Floor	Veiltail
Grifols	Second Floor	Labrid A
Guaranteed Returns	Second Floor	Unicorn
Johnson & Johnson	Second Floor	Bluegill
KRS Global	Second Floor	The Upper Deck
Mallinckrodt	Second Floor	Hinalea
McKesson	Second Floor	Grouper
Metro	Second Floor	Zander
Pacira	First Floor	Atlantis B
PharMEDium	Second Floor	Nomeus
Prodigy Health	Second Floor	Fantail
Progressive Medical Inc.	Second Floor	Palani B
Reliance Wholesale Inc.	Second Floor	Labrid B
Salix Pharmaceuticals, Inc.	Second Floor	Cobia
Swisslog	Second Floor	Palani A
Truven Health Analytics	Second Floor	Anemone





DINNER & ENTERTAINMENT



JOIN US AT SEAWORLD'S PORTS OF CALL

On Tuesday night, dress in your favorite Aloha attire and join us for a relaxing Caribbean-themed escape at SeaWorld's Ports of Call. Ports of Call, a nautical wharf-side warehouse district inside SeaWorld Orlando's theme park, is one of the city's premier private event venues set in a lush, tropical landscape complete with waterfalls and two miniature submarines. With live animal experiences, rock n' roll dueling pianists from Howl at the Moon, fantastic food, and an open bar, come prepared for a wonderful night of networking and entertainment.

Shuttles will run continuously between the Renaissance Orlando at SeaWorld and Ports of Call from 5:50 pm - 10:00 pm.

SPONSORED BY



Premium Sponsor for
2015 HCP Conferences



AGGR[^]STAT[®]

tirofiban HCl

New Dosing. Proven Efficacy.

ACC/AHA/SCAI Guideline Recommended

Find out why hospitals are switching to Aggrastat.

Contact a Product Specialist

1.866.695.8242

AggrastatHDB@medicure.com

For More Product Information Visit

www.AggrastatHDB.com

Aggrastat is a registered trademark of Medicure Pharma. © 2015 Medicure Pharma. All rights reserved.



Over the past year, this committee volunteered their valuable time to help us create an outstanding agenda.

We appreciate their energy and want to recognize this esteemed group for all their hard work.

Without their expertise, this event would not have been possible.



HOSPITAL PHARMACY BOARD CHAIR:

MARSHALL ROBBINS, PharmD

Director of Pharmacy
Crestwood Medical Center
Huntsville, AL

Anthony Antonopoulos, RPh, MBA

Executive Director, Regional Pharmacy Svcs
St. Vincent Hospital and Healthcare System
Indianapolis, IN

James DeFazio, RPh

Director Clinical Value Analysis & Pharmacy
Bon Secours Health System, Inc.
Columbia, MD

Mary Helen Bowen, RPh

Assistant VP, Pharmacy Services
St. Dominic Hospital
Jackson, MS

James Eldridge, PharmD, MBA

Dir, Pharmacy Utilization and Operations
HealthTrust - HCA
Brentwood, TN

Ruth Cassidy, B.S. PharmD FACHE

Vice President of Clinical Services
SBH Health System
Bronx, NY

John Jones, RPh

Vice President
Geisinger Health System
Danville, PA

Arash Dabestani, PharmD, MHA, FASHP, FABC

Senior Director of Pharmacy
NYU Langone Medical Center
New York, NY

Richard Mendribil, PharmD

Health System Director of Pharmacy
Northern Arizona Health
Flagstaff, AZ

Venita Papillion, PharmD

Director, Clinical Pharmacy Services
Catholic Health Initiatives
Engelwood, CO



TUESDAY MAY 5

OPENING REMARKS AND KEYNOTE ADDRESS

8:00 AM - 9:30 AM • Crystal Ballroom
1.5 hours

KEYNOTE SPEAKER: Dr. Jason Selk

While serving as the Director of Mental Training for the St. Louis Cardinals, Dr. Jason Selk helped the team win their first World Series in over 20 years, and in 2011 he assisted the Cardinals in the historic feat of winning their second World Championship in a six year period. Dr. Selk is a regular contributor to *Forbes*, *INC*, *Success*, *Shape*, and *Self Magazine*; ABC, CBS, ESPN, and NBC radio and television; and has been featured in *USA Today*, *CNBC*, and *Men's Health*. Dr Selk's second book, *Executive Toughness*, is a best-selling business book and his first book, *10-Minute Toughness*, is on pace to be one of the best-selling sport psychology books of all time.



Session sponsored by:



Dr. Selk is considered to be one of the premier performance coaches in the United States. He helps numerous well-known professional and Olympic athletes as well as Fortune 500 and Fortune 100 executives and organizations develop the mental toughness necessary for high-level success.

In this keynote presentation, **Relentless Solution Focus (RSF): The Ultimate Measure of Mental Toughness**, attendees will learn to use the tool that allows individuals to overcome all obstacles of achievement. RSF is a concrete and proven method of increasing individual health, happiness and success and by extension produces organizations that are healthier, happier and more successful. Each attendee will once and for all develop the positive mindset needed to outperform the competition.

LEARNING OBJECTIVES:

At the completion of this activity, the participant will be able to:

- Describe Problem Centric Thought (PCT) Alert System – knowledge of how to avoid the “PCT disadvantage”
- Discuss RSF Tool-Motivation and ability to replace all negative thinking with solution focused thought within 60 seconds
- Identify Solution Focused Meeting Protocol and how it can be the simple yet effective manner to make all meetings more efficient and productive





TUESDAY MAY 5

HAZARDOUS DRUGS - PART 1

A New USP Chapter for Protecting Patients and Practitioners

9:45 AM - 10:45 AM • Crystal Ballroom

Speaker: Eric Kastango, MBA, RPh, FASHP

CEO & President

Clinical IQ, LLC

Hazardous drug compounding occurs frequently in inpatient and ambulatory settings. Though most of the medications are sterile compounds, manipulation of non-sterile hazardous medications also occur. Three documents that lead practice decisions concerning handling hazardous drugs are in the process of being revised or released: the 2014 NIOSH List of Antineoplastic and Other Hazardous Drugs in Healthcare Settings, the 2004 NIOSH Alert (under revision) and new proposed USP Chapter <800>. This program will identify the current status of compounding with hazardous drugs, including facility and personnel requirements, environmental monitoring, and personnel safety issues, and outline the requirements and recommendations health systems need to safely provide services involving hazardous drugs.



Eric Kastango is president of Clinical IQ LLC, a health care consulting firm and CriticalPoint, LLC, a web-based education company. Eric received his Bachelor of Science degree in Pharmacy from the Massachusetts College of Pharmacy and Allied Health Sciences and his Master of Business Administration degree from the University of Phoenix. He is also the 2014 recipient of the NABP Henry Cade Memorial Award that recognized the efforts and assistance to the states and NABP to address the compounding tragedy that occurred in 2012.

Since 1980, he has practiced pharmacy in a number of practice settings, including hospitals, community and home care, and in a number of different of roles, including the Corporate Vice President of Pharmacy Services for Coram Healthcare Corporation. He has also managed a FDA-registered cGMP manufacturing operation for Baxter Healthcare Corporation. He is an active member and Fellow of the American Society of Healthcare Pharmacists and served on the USP Sterile Compounding Committee from 2005-2010 and 2010-2015 USP Council of Experts, Compounding Expert Committee until April 2013. He is currently an Expert Consultant to the USP and is actively working with NABP and state boards of pharmacy to provide training to their sterile compounding inspectors.

Sessions sponsored by:



LEARNING OBJECTIVES:

At the completion of this activity, the participant will be able to:

- Summarize the key non-compliant issues concerning hazardous drugs
- Describe the various state and national initiatives designed to protect healthcare workers handling hazardous drugs
- Understand the major proposed requirements of the new USP hazardous drug chapter
- Define the ideal facility design elements for inpatient and ambulatory practice sites

Sessions sponsored by:



HAZARDOUS DRUGS - PART 2

A New USP Chapter for Protecting Patients and Practitioners

11:00 AM - 12:00 PM • Crystal Ballroom

2 hours / Parts 1 & 2



TUESDAY MAY 5

CONTROL SUBSTANCE DRUG DIVERSION

What keeps us up at night and closing the gaps to get a full night sleep

1:15 PM - 2:30 PM • Crystal Ballroom
1.25 hours

Speaker: Christopher R. Fortier, PharmD, FASHP

Chief Pharmacy Officer
Massachusetts General Hospital

Christopher Fortier is the Chief Pharmacy Officer at the Massachusetts General Hospital in Boston, MA. He serves as an Adjunct Associate Professor at the University of Connecticut School of Pharmacy, Northeastern University School of Pharmacy, and the Massachusetts College of Pharmacy. In 2010, Chris was selected to represent South Carolina as a voting member at the ASHP/ASHP Foundation's Pharmacy Practice Model Initiative Summit. He is currently the UHC Pharmacy Council's Executive Committee Member-At-Large and previously served 3 years on the University HealthSystem Consortium's (UHC) Pharmacy Council's Executive Committee and chaired the Medication Use Informatics and Technology Committee. Chris received his Doctor of Pharmacy degree from the University of Connecticut and completed both a PGY-1 Practice Residency and a PGY-2 Health-System Pharmacy Administration Residency at the Medical University of South Carolina Medical Center. Previously he was the Manager of Pharmacy Support and Operating Room Services at the Medical University of South Carolina (MUSC) Medical Center.



Session sponsored by:

swisslog
inspired solutions

LEARNING OBJECTIVES:

At the completion of this activity, the participant will be able to:

- Describe a large academic medical center's experience around control substance drug diversion and a regulatory agency's internal investigation
- Discuss the specific drug diversion process improvement initiatives, policy development, and optimization between pharmacy, nursing, anesthesia and hospital security
- Outline the lessons learned and potential system gaps when implementing a comprehensive diversion surveillance program and consistent compliance around regulatory reporting requirements

PLEASE NOTE:

BE SURE TO HAVE YOUR NAME BADGE SCANNED BEFORE EACH EDUCATIONAL SESSION. CE CREDIT WILL BE AWARDED BASED ON BADGE SCANS PER SESSION.



Educational Review Systems is accredited by the Accreditation Council for Pharmacy Education (ACPE) as a provider of continuing pharmaceutical education. This program is approved for up to 5.75 hours (0.575 CEUs) of continuing pharmacy education credit. Proof of participation will be posted to your NABP CPE profile within 4 to 6 weeks. Participants must participate in the entire presentation and complete the course evaluation to receive continuing pharmacy education credit.



WEDNESDAY MAY 6

BIOSIMILARS - IMPLICATIONS FOR HOSPITALS AND HEALTH SYSTEMS

8:00 AM - 9:00 AM • Crystal Ballroom
1 hour

Speakers:

Burnis D. Breland, MS, PharmD, FASHP

Burnis D. Breland is an independent health system consultant and educator and has recently assumed the role as manager, 340B compliance and education support with Apexus / 340B Prime Vendor Program. He served as Director of Pharmacy at The Medical Center, Columbus Regional Health, Columbus, Georgia for over 30 years where he also served in various roles including Administrative Director of Oncology, Director of Clinical Research, Director of Infusion Services, and Director of the Transition of Care Clinic. He has served as Affiliate Clinical Professor, Department of Pharmacy Practice, Auburn University; preceptor for the University of Georgia, Mercer University, and South University Schools of Pharmacy; and Director of the Pharmacy Residency Programs at Columbus Regional. Dr. Breland received his Doctor of Pharmacy from the University of Tennessee in Memphis, and was recognized as a Fellow of ASHP in 1991. He is a recipient of the ASHP Best Practices award, the ASHP & Northeastern University Webb Lecture award, the Abbott Quality Pharmacy award, the GPhA Innovative Pharmacy Practice award, two time recipient of the GSHP Hospital Pharmacist of the Year award, and recipient of the GSHP Community Service award. He has authored articles and book chapters published in the pharmacy and medical literature.



Steven Lucio, PharmD, BCPS

Steven Lucio is Senior Director of Clinical Solutions and Pharmacy Program Development at Novation, a health care supply chain and analytics company in Irving, Texas. During his tenure at Novation, he has had responsibility for providing education to member organizations and supporting their efforts on various clinical practice topics including improving medication safety,



managing hazardous pharmaceutical waste, mitigating the impact of drug shortages, benchmarking pharmacy costs for key drug classes, evaluating the expense of high cost biologics and specialty drugs and preparing for the future development of biosimilar medications. Prior to joining Novation, Steven practiced for almost 10 years within the Baylor Health Care System in both inpatient and ambulatory care. Steven holds a PharmD from Creighton University, a Bachelor of Science in Pharmacy from the University of Texas at Austin, and is a Board Certified Pharmacotherapy Specialist. He is author of several recent publications on the topic of biosimilars.

Session sponsored by:



LEARNING OBJECTIVES:

At the completion of this activity, the participant will be able to:

- Describe the current status of biosimilars including the approval process for biologically similar products in the United States.
- Discuss the differences in small molecule drug compounds and biological therapeutic agents including the differences in the manufacturing processes, variability between products, and the potential for clinically significance variations.
- Identify biosimilars that are currently under review by the FDA and other potential biosimilar products that may be introduced into the U.S. market in the near future.
- Evaluate the current status of the US biosimilars regulatory pathway and the litigation that will determine the timing of competition in the biologics market.
- Discuss the European experience with biosimilars and what can be done to drive even greater uptake in the US.
- Discuss considerations for evaluation and acceptance of biosimilars by hospitals and health systems.
- Discuss the potential financial impact of biosimilars on health systems and market variables which may affect utilization and product competitiveness.

Clinical Drug Information

Whatever your drug information needs may be, we have you covered!



Clinical Drug Information

- Lexicomp®
- Facts & Comparisons®
- Medi-Span®

Offering a complete medication decision support solution:

- Online
- EMR Data
- Mobile
- System Integration
- Custom Formulary
- Patient Education



OCEANS BALLROOM

Session 1: Tuesday, May 5, 3:00 PM - 5:00 PM

Session 2: Wednesday, May 6, 9:30 AM - 11:30 AM

In the Reverse EXPO sessions, Hospital Pharmacy Directors and GPO Executives host exhibit tables while suppliers walk through the hall. This unique event is a fun change of pace from traditional expo formats and provides the best networking opportunity for both providers and suppliers.

On the next page, you will find a map outlining the location of each booth in the hall. Please refer to the list of specific booth assignments (pages 29 - 42) to locate each provider executive during the Reverse EXPO.

SPONSORED BY:



CANTRELL
DRUG COMPANY

EXHIBIT HALL



	1500	1501	1502	1503	1504	1505	1506	1507	1508	1509	1510	1511	1512	1513	1514	1515	1516	1517	1518	1519	1520	1521	1522	1523	1524	1525	1526	
120																												1418
119	220	320				420	520				620	720			820	920			1020	1120			1220	1320				1417
118	219	319				419	519				619	719			819	919			1019	1119			1219	1319				1416
	218	318				418	518				618	718			818	918			1018	1118			1218	1318				1415
116	217	317				417	517				617	717			817	917			1017	1117			1217	1317				1414
115	216	316				416	516				616	716			816	916			1016	1116			1216	1316				1413
114	215	315				415	515				615	715			815	915			1015	1115			1215	1315				1412
113	214	314				414	514				614	714			814	914			1014	1114			1214	1314				1411
112	213	313				413	513				613	713			813	913			1013	1113			1213	1313				1410
	212	312				412	512				612	712			812	912			1012	1112			1212	1312				1409
	211	311				411	511				611	711			811	911			1011	1111			1211	1311				1408
108																												1407
107	208	308				408	508				608	708			808	908			1008	1108			1208	1308				1406
106	207	307				407	507				607	707			807	907			1007	1107			1207	1307				1405
105	206	306				406	506				606	706			806	906			1006	1106			1206	1306				1404
104	205	305				405	505				605	705			805	905			1005	1105			1205	1305				1403
103	204	304				404	504				604	704			804	904			1004	1104			1204	1304				1402
102	203	303				403	503				603	703			803	903			1003	1103			1203	1303				1401
101	202	302				402	502				602	702			802	902			1002	1102			1202	1302				1400
100	201	301				401	501				601	701			801	901			1001	1101			1201	1301				1400
	200	300				400	500				600	700			800	900			1000	1100			1200	1300				1400

YOUR TRUSTED SOURCE

Please visit our
Hospitality Suite on Monday
evening for our famous
"Phrozen Pharmaceuticals"
Walu, 2nd level



Lance Lanier, BS Pharmacy
Director Business
Development

Tracye Easterly
Administration

Mike Pierce
President

Dell McCarley, Pharm D
Chairman/CEO

Raymond C. Anderson, PhD
VP Quality Assurance &
Regulatory Affairs

Susan Tyger
Account Representative

Chris Hutts, Pharm D
Pharmacist in Charge



CANTRELL DRUG COMPANY

Pharmaceutical Outsourcing Specialists

FDA Registered 503B Human Drug Compounding Outsourcing Facility

Our experience with cGMP-focused policies and procedures along with carefully designed facilities, equipment, training and testing, provide confidence to our customers in the quality of our services.

QUALITY › SERVICE › EXPERIENCE

877-666-5222
www.cantrelldrug.com

PROVIDER ATTENDEES LIST BY FACILITY



Adventist Health System

Booth # 1013
Altamonte Springs, FL
Greg Strohs, MBA, RPh
Corporate Director of Pharmacy
Outpatient Pharmacy

Adventist LaGrange Memorial Hospital

Booth # 704
LaGrange, IL
David Tsang
Director of Pharmacy

Alvarado Hospital

Booth # 805
San Diego, CA
Cam Tran
DOP
Outpatient Pharmacy

Amerinet, Inc.

Booth # 1113
St. Louis, MO
Stacey Winston
Sr. Director, Contracting Solutions

Amerinet, Inc.

Booth # 1112
St. Louis, MO
Ryan Soehlig
Director, Pharmacy Specialist

AnMed Health Medical Center

Booth # 420
Anderson, SC
Tim Hipp, RPh, MS
Director of Pharmacy Services
Outpatient Pharmacy

Archbold Medical Center

Booth # 217
Thomasville, GA
Chris Newman
Director of Pharmacy Services

Arkansas Methodist Medical Center

Booth # 318
Paragould, AR
Stan Carmack, Pharm.D.
Director of Pharmacy
Outpatient Pharmacy

Aroostook Medical Center

Booth # 1412
Presque Isle, ME
Paul Barrett, PharmD, MPA, BCPS, FASHP, CPHQ
Manager

Arrowhead Regional Medical Center

Booth # 808
Colton, CA
Marvin Finnefrock, Pharm D
VP of Clinical Pharmacy

Aultman Hospital

Booth # 1212
Canton, OH
James Toohey, MS, RPh
Executive Director of Pharmacy
Outpatient Pharmacy

Avera Health

Booth # 1000
Sioux Falls, SD
Steve Petersen, PharmD
Vice President - Pharmacy
Outpatient Pharmacy

Avera St. Luke's Hospital

Booth # 1001
Aberdeen, SD
Alvin Haugen, PharmD
Pharmacy Director

Banner Compounding Pharmacy

Booth # 600
Chandler, AZ
Misty Vo, PharmD, MSPHarm
Pharmacy Director

Baptist Health

Booth # 207
Montgomery, AL
Clinton Peevy, Pharm.D.
System Director of Pharmacy Services
Outpatient Pharmacy

Baptist Medical Center South

Booth # 208
Montgomery, AL
Gary Mount
Director of Pharmacy

Baptist Memorial Hospital - North MS

Booth # 306
Oxford, MS
Andrew Sweeney
Director of Pharmacy
Outpatient Pharmacy

Baton Rouge General Medical Center Mid City

Booth # 314
Baton Rouge, LA
Pam Nogueira, R.Ph.
Manager
Outpatient Pharmacy

Baton Rouge General Med Center Blue Bonnet

Booth # 315
Baton Rouge, LA
Michael Dorman, R.Ph.
Director of Pharmacy
Outpatient Pharmacy

Baxter Regional Medical Center

Booth # 319
Mountain Home, AR
Angela Powell, PharmD
Director of Pharmacy
Outpatient Pharmacy

Beebe Medical Center

Booth # 1512
Lewes, DE
Samuel Roberts
Director of Pharmacy

Beth Israel Deaconess Hospital-Plymouth

Booth # 1501
Plymouth, MA
Kristina McGill, MS, RPh
Director of Pharmacy

Bethesda North Hospital

Booth # 1213
Cincinnati, OH
Sue McBeth, RPh, MBA
Director of Pharmacy
Outpatient Pharmacy

Beverly Hospital

Booth # 814
Montebello, CA
Wayne Campbell, Pharm D
Director of Pharmacy

Boca Raton Regional Hospital

Booth # 201
Boca Raton, FL
Gwenesia Collins, PharmD
Director of Pharmacy

Boca Raton Regional Hospital

Booth # 202
Boca Raton, FL
Emmanuel Markakis, PharmD
Clinical Pharmacy Manager

Bon Secours Health System, Inc.

Booth # 1513
Columbia, MD
James DeFazio, RPh
Director Clinical Value Analysis & Pharmacy
Outpatient Pharmacy

Bridgeport Hospital

Booth # 1505
Bridgeport, CT
Russell Sage, BS, RPh
Manager, Pharmacy Operations

Bristol Hospital

Booth # 1506
Bristol, CT
Steve Burke
Director of Pharmacy

PROVIDER ATTENDEES LIST BY FACILITY

**Bristol Regional Medical Center**

Booth # 402
Bristol, TN
Dwight Owens, PharmD
Director of Pharmacy

Broward Health - Coral Springs Med Center

Booth # 103
Coral Springs, FL
Lisa Colodny, PharmD, MBA
Director of Pharmacy

Canton-Potsdam Hospital

Booth # 1400
Potsdam, NY
Christopher Boiallis, PharmD.
Director of Pharmacy

Cape Cod Healthcare

Booth # 1417
Hyannis, MA
Peter Scarafale, RPH, MS
Director of Pharmacy
Outpatient Pharmacy

Capital Region Medical Center

Booth # 1016
Jefferson City, MO
John Hamilton, Pharm. D.
Director of Pharmacy
Outpatient Pharmacy

Carilion Clinic

Booth # 518
Roanoke, VA
Clara Anne Spencer, R.Ph.
Director of Pharmacy Contracting
Outpatient Pharmacy

Carilion Clinic

Booth # 517
Radford, VA
William Lee, D.Ph, MPA, FASCP
System Pharmacy Director

Carroll Hospital Center

Booth # 1516
Westminster, MD
Larry Siegel, PharmD
Director of Pharmacy

Carter-Coler Specialty Hospital

Booth # 1317
New York, NY
Richard Wenzel
Director of Pharmacy

Catholic Health Initiatives

Booth # 917
Englewood, CO
Venita Papillion, PharmD
Director, Clinical Pharmacy Services

Centennial Hills Hospital Medical Center

Booth # 912
Las Vegas, NV
Andrew Jackson, Pharm.D.
Director of Pharmacy
Outpatient Pharmacy

Centerpoint Medical Center

Booth # 1107
Independence, MO
Terry Glazier, R.Ph.
Director of Pharmacy

CentraCare Health

Booth # 1005
St. Cloud, MN
Jennifer Hagen
Director of Ambulatory Pharmacy Services
Outpatient Pharmacy

CGH Medical Center

Booth # 1220
Sterling, IL
Tim Dunphy, RPh
Pharmacy Director

Charlton Mem Hospital / Southcoast Hospital

Booth # 1500
Fall River, MA
John Evans, RPh, MS, MBA
Executive Director of Pharmacy

CHI-FH Highline Medical Center

Booth # 907
Burien, WA
Thuy Vo, PharmD
Director of Pharmacy Services

Children's Hospital Los Angeles

Booth # 815
Los Angeles, CA
Karen Berry
Pharmacy Purchasing Mgr

Christus Health

Booth # 614
Irving, TX
Myra Thomas, RPh
Director Resource Utilization Pharmacy

CHRISTUS Health

Booth # 613
Irving, TX
Aaron Bailey, PharmD
Director of Pharmacy

Christus Health SETX

Booth # 615
Beaumont, TX
Thomas Welch, RPh
Pharmacy Director

Christus Santa Rosa Hospital-Alamo Heights

Booth # 616
San Antonio, TX
Howard McClelland, BS, MS, RPh
Director of Pharmacy
Outpatient Pharmacy

CHRISTUS Spohn Hospital Corpus Christi-South

Booth # 617
Corpus Christi, TX
Elias Cavazos, RPh
Director of Pharmacy

CHRISTUS Spohn Hospital -Shoreline

Booth # 618
Corpus Christi, TX
Vladimir Dvorkin
Director of Pharmacy

CHRISTUS St. Frances Cabrini Hospital

Booth # 611
Alexandria, LA
Jude Lemoine
Director of Pharmacy
Outpatient Pharmacy

CHRISTUS St. Michael Health System

Booth # 619
Texarkana, TX
Dale Smith, RPh
Director of Pharmacy
Outpatient Pharmacy

CHRISTUS St. Patrick Hospital

Booth # 612
Lake Charles, LA
Shanna Thibodeaux
Director of Pharmacy

Citizens Medical Center

Booth # 620
Victoria, TX
Bill Reeves, PD, RPh, MBA, ACHE
Director of Pharmacy

Claxton-Hepburn Medical Center

Booth # 1401
Ogdensburg, NY
Greg Guimond, RPh
Director of Pharmacy

Colquitt Regional Medical Center

Booth # 218
Moultrie, GA
Matthew Clifton, PharmD
Director of Pharmacy Services

Columbus Regional Health

Booth # 216
Columbus, GA
Debbie Nowlin, RPh
Director of Pharmacy
Outpatient Pharmacy



**Is Your Purchasing Group Still Just Chasing Rainbows?
PDM Healthcare—your trusted business partner.**

Learn How Your Business Really Stacks Up!



WATCH YOUR PROFITS GROW WITH PDM!

- SUPPLY CHAIN MANAGEMENT SOLUTIONS**
- GROUP PURCHASING**
- CONTINUING EDUCATION**
- DISEASE STATE MANAGEMENT**
- CAPITAL EQUIPMENT FINANCING**
- TECHNOLOGY SOLUTIONS**
- REIMBURSEMENT RECONCILIATION**

CONTRACT PORTFOLIO AVAILABLE THROUGH PDM HEALTHCARE

- AUTOMATIC AND NEEDLELESS INJECTORS
- BRANDED, SPECIALTY & GENERIC PHARMACEUTICALS
- BLOOD GLUCOSE METERS
- BLOOD SAMPLING INSTRUMENTS
- BLOOD PRESSURE INSTRUMENTS
- CHOLESTEROL SAMPLING INSTRUMENTS
- CONSUMER AND INSTITUTIONAL SUPPLIES
- CONTINUOUS GLUCOSE MONITORS
- DIAGNOSTIC TOOLS
- DIETARY AND WEIGHT MANAGEMENT PROGRAMS
- EDUCATIONAL PRODUCTS & TEACHING AIDS
- WOUND CARE
- EXERCISE EQUIPMENT
- EYE CARE/VISION SCREENING
- FOOTWEAR AND PODIATRIC CARE
- HEALTHY FOOD/NUTRITIONAL SUPPLEMENTS
- HME/DME SUPPLIES
- INPATIENT TREATMENT PROGRAMS
- INSULIN DELIVERY SYSTEMS
- LABORATORY SUPPLIES
- MARKET RESEARCH
- MEDICAL SUPPLIES
- MOBILITY AIDS
- NEEDLE AND LANCET DISPOSAL
- NUTRITIONAL PRODUCTS
- OFFICE SUPPLIES & EQUIPMENT
- OVER THE COUNTER MEDICINE
- ORAL AGENTS
- ORAL HEALTH/DENTAL CARE
- PRESCRIPTION DRUGS
- SKIN CARE, HAND/NAIL PRODUCTS
- STAFFING SERVICES
- SOFTWARE
- STORAGE & TRAVEL KITS



PROVIDER ATTENDEES LIST BY FACILITY



Columbus Regional Hospital

Booth # 1211
Columbus, IN
Ben Caughey, Pharm.D., B.S.
Director of Pharmacy
Outpatient Pharmacy

Community Health Systems

Booth # 603
Albuquerque, NM
William Lord
Regional Pharmacy Director

Community Health Systems

Booth # 1413
Salem, NJ
Tracie Chambers, RPh
Regional Director of Pharmacy

Concord Hospital

Booth # 1415
Concord, NH
David DePiero, MS, RPh
Manager, Medication Utilization

Conway Medical Center

Booth # 504
Conway, SC
Robert Gajewski, BS Pharmacy
Director of Pharmacy
Outpatient Pharmacy

Coosa Valley Medical Center

Booth # 211
Sylacauga, AL
Donald Haley, RPh., BSPHarm
Pharmacy Director

Covenant Medical Center

Booth # 1006
Waterloo, IA
John Hamiel, PharmD
Director of Pharmacy
Outpatient Pharmacy

Covenant Medical Inc. Harrison

Booth # 1118
Saginaw, MI
Terry Wernette, Rph
Director of Pharmacy
Outpatient Pharmacy

Cox Health

Booth # 1017
Springfield, MO
Louis Kynard, Pharm D. MBA
System Director of Pharmacy

Crestwood Medical Center

Booth # 205
Huntsville, AL
Marshall Robbins, PharmD
Director of Pharmacy

Crouse Hospital

Booth # 1402
Syracuse, NY
Barbara McNiff, PharmD
Director of Pharmacy

Dallas Regional Medical Center

Booth # 807
Mesquite, TX
Ken Spear, R.Ph. M.B.A.
Director of Pharmacy

Deborah Heart and Lung Center

Booth # 1520
Browns Mills, NJ
Deborah Sadowski, RPh, MHA
Director of Pharmacy Services

DeKalb Regional Medical Center

Booth # 206
Fort Payne, AL
David Martin, PharmD, FACN, CNS, FASCP
Director of Pharmacy

Desert Springs Hospital

Booth # 913
Las Vegas, NV
Evelyn Chu, Pharm D BCPS
Director of Pharmacy

Dimensions Healthcare System

Booth # 1517
Cheverly, MD
Demetris Butler
Corp. Pharmacy Director

Doylestown Hospital

Booth # 1311
Doylestown, PA
Louis Iobbi, RPh
Director of Pharmacy

Elliot Health System

Booth # 1416
Manchester, NH
Joe Glew
Director of Pharmacy Services

Ephraim McDowell Regional Medical Center

Booth # 407
Danville, KY
Joan Haltom, PharmD
Director of Pharmacy
Outpatient Pharmacy

Falmouth Hospital (Cape Cod Healthcare)

Booth # 1418
Falmouth, MA
James Mangan
Pharmacy Operations Manager

Federation of American Hospitals

Booth # 1306
Washington, DC
Kerry Price
Senior VP of Administration Services

FL Hospital Memorial Med Ctr (Adventist)

Booth # 107
Daytona Beach, FL
Marshall Hughey
Director of Pharmacy

Florida Hospital Flagler

Booth # 106
Palm Coast, FL
Michael DeBusk, PharmD, MBA
Director of Pharmacy

Flowers Hospital

Booth # 212
Dothan, AL
Joe Dalton, RPh
Pharmacy Director

Floyd Medical Center

Booth # 219
Rome, GA
Robert Purcell, PharmD
Director, Pharmacy Services

Forrest City Medical Center

Booth # 401
Forrest City, AR
Lakesha Farmer, PharmD
Director of Pharmacy

Franciscan Alliance (Central Indiana Region)

Booth # 1205
Indianapolis, IN
Ronda Freije, MBA, RPh
Director of Pharmacy
Outpatient Pharmacy

Franciscan St. Francis Health

Booth # 1206
Mooresville, IN
Alan Alfrey, R.Ph.
Pharmacy Manager

Franciscan St. Margaret Health-North Campus

Booth # 1207
Hammond, IN
Sun Lee-Such, PharmD, FACHE, MBA
Director of Pharmacy

Freeman Health System

Booth # 1018
Joplin, MO
Jeffery Thompson, PharmD
Vice President of Pharmacy Services

Facing the reality of empty promises?



When choosing medication automation, you want to make sure it will live up to expectations—now and in the future. The proven Omnicell® Unity enterprise platform delivers. It streamlines workflow by integrating medication, supply, and central pharmacy automation systems on a single database, and keeps your technology up to date through annual software upgrades. Join the over 1,800 health care facilities that are saving time, reducing interruptions, and increasing medication security since choosing the Unity platform.

Omniceil—Proven, not just promised.

“We found that Omnicell’s advanced technology is unparalleled in the market. Omnicell’s interoperability, user-friendly interface and forward-thinking approach to medication management set them apart in our search.”

Jeff St. Clair
President and CEO
Springhill Medical Center



Take on Tomorrow. Call 855-306-7926 or visit www.Omniceil.com to learn more.

Omniceil was ranked Best in KLAS for Automated Medication Dispensing Units from 2010 - 2014. Best in KLAS Awards—Medical Equipment & Infrastructure Reports, 2006-2014. ©2014 KLAS Enterprises LLC. All rights reserved. www.KLASresearch.com

PROVIDER ATTENDEES LIST BY FACILITY



Geisinger Health System

Booth # 1307
Danville, PA
John Jones, RPh
Vice President
Outpatient Pharmacy

Geisinger-Lewistown Hospital

Booth # 1308
Lewistown, PA
Richard Stomackin, BS Pharm, R.Ph.
Director of Pharmacy
Outpatient Pharmacy

George Washington University Hospital

Booth # 1510
Washington, DC
Renia Mathews, PharmD
Director of Pharmacy

Georgetown Hospital System

Booth # 502
Pawleys Island, SC
Ambrose Holliday, BSPHarm, RP
Director of Ambulatory Pharmacy Services

Good Samaritan Hospital

Booth # 1208
Vincennes, IN
Jim Eskew
Pharmacy Director
Outpatient Pharmacy

Good Samaritan Hospital

Booth # 906
San Jose, CA
Trang Le, PharmD, MHA
Director of Pharmacy

Good Samaritan Hospital (CHI)

Booth # 1003
Kearney, NE
Nicki Bohl, PharmD
Director of Pharmacy

Good Shepherd Rehabilitation Hospital

Booth # 1312
Allentown, PA
Robert Shuminski, RPh, MBA
Director of Pharmacy

Great River Health Systems

Booth # 1007
West Burlington, IA
Darwin Cooley
Director of Pharmacy

Greenville Health System

Booth # 505
Greenville, SC
Fredrick Bender, PharmD
Director of Pharmacy Services
Outpatient Pharmacy

Gulf Coast Regional Medical Center (HCA)

Booth # 112
Panama City, FL
Michelle Franklin, Pharm. D.
Director of Pharmacy

Gundersen Health System

Booth # 1114
La Crosse, WI
Jolene Garrett, Pharm.D., BCPS
Pharmacy Director
Outpatient Pharmacy

Hamilton Medical Center

Booth # 220
Dalton, GA
Gregory Stinnett, RPh
Director of Pharmacy

Harlingen Medical Center

Booth # 806
Harlingen, TX
Mitchell Everett, RPh
Director of Pharmacy

Harvard University Health Services

Booth # 1502
Cambridge, MA
Benedict DiRusso
Director of Pharmacy

HCA Healthcare

Booth # 406
Nashville, TN
Nicole Bryan, PharmD, MBA
Dir, Performance Improvement-Pharmacy

HCA Henrico Doctors' Hospital

Booth # 513
Richmond, VA
Cynthia Nester, PharmD
Director of Pharmacy

HCA Parham Doctors' Hospital

Booth # 514
Richmond, VA
Courtney Fuller
DOP

Health Central Hospital

Booth # 105
Ocoee, FL
Bhavna Patel
Assistant Director of Pharmacy

HealthTrust

Booth #1305
Brentwood, TN
Craig Coulter
Director, Pharmacy Strategic Sourcing

Hillcrest Med Ctr / Cardinal Health

Booth # 718
Tulsa, OK
Bradley Atherton, D.Ph
Director of Pharmacy Services
Outpatient Pharmacy

Holy Cross Hospital - Chicago IL

Booth # 1219
Chicago, IL
Andrew Volk, PharmD, BCPS
Pharmacy Operations Manager

Hospital of Central Connecticut

Booth # 1507
New Britain, CT
David Girouard
Central Region Director of Pharmacy

Houston Healthcare System

Booth # 300
Warner Robins, GA
Nattie Rogers
Director of Pharmacy

Huntington Memorial Hospital

Booth # 816
Pasadena, CA
Jean Pallares, PharmD
Dir of Pharmacy and Laboratory Services

Huntsville Hospital

Booth # 203
Huntsville, AL
Michael McDaniel, RPh, MBA, FASHP
Director of Pharmacy
Outpatient Pharmacy

Huntsville Hospital: Women/Children & Retail

Booth # 204
Huntsville, AL
Susan Robbins, RPh
Pharmacy Manager
Outpatient Pharmacy

Hurley Medical Center

Booth # 1119
Flint, MI
Amy Benko
Director of Pharmacy

Hutcheson Medical Center

Booth # 301
Fort Oglethorpe, GA
Holly Trotter
Director of Pharmacy

Inspira Medical Center Vineland

Booth # 1521
Vineland, NJ
Sabrina Romean, RPh, JD
Director of Pharmacy

PROVIDER ATTENDEES LIST BY FACILITY



Jefferson Regional Medical Center

Booth # 320
Pine Bluff, AR
Lelan Stice, PD, MBA
Administrative Director of Pharmacy
Outpatient Pharmacy

Johnston Willis Hospital

Booth # 515
Richmond, VA
Jake Howson, PharmD
Clinical Specialist

Kettering Health Network

Booth # 1214
Kettering, OH
Skip Hickman, RPh
Network Manager Pharmaceutical Sourcing

Kindred Corporate - PharMerica (22 Hospitals)

Booth # 811
Redding, CA
John Choi
Senior Director of Operations Pharmacy

Kindred Health / PharMerica

Booth # 812
Louisville, KY
Charles Ham, Pharm.D, MBA
Director, Clinical & Regulatory Services

Kindred Hospital-Houston

Booth # 813
Houston, TX
Nicholas Enow, PharmD, BCNSP
Director of Pharmacy

Kings County Hospital Center

Booth # 1403
Brooklyn, NY
Joseph Abinanti, MS, RPh
Director of Pharmacy Services
Outpatient Pharmacy

Lake Regional Health System

Booth # 1019
Osage Beach, MO
Tom Myler
Director of Pharmacy

Lake Wales Medical Center

Booth # 108
Lake Wales, FL
Kennetha Colorado-Tiner, PharmD
Director, Pharmacy Services

Lawrence & Memorial Hospital Systems

Booth # 1508
New London, CT
Warren Rogers, RPh
Director of Pharmacy Services
Outpatient Pharmacy

Lehigh Valley Hospital–Muhlenberg

Booth # 1313
Bethlehem, PA
Rhonda Thomas, Pharm D, MBA
Director of Pharmacy

Los Angeles County Harbor-UCLA Med Ctr

Booth # 817
Torrance, CA
Jennie Ung, Pharm.D.
Pharmacy Director

Lourdes Health System

Booth # 1522
Camden, NJ
William Haigh
Assistant Director

Loyola University Medical Center

Booth # 1300
Maywood, IL
William Pong
Administrative Pharmacy Director

Madison Memorial Hospital

Booth # 916
Rexburg, ID
Dorsie Sullenger
Director of Pharmacy

Manatee Memorial Hospital

Booth # 116
Bradenton, FL
Kirsten Parker, PharmD,CGP, BCPS
Pharmacy Clinical Coordinator

Mary Lanning Memorial HealthCare

Booth # 1004
Hastings, NE
Debra Lee,
Director of Pharmacy

Massachusetts General Hospital

Booth # 1503
Boston, MA
Chris Fortier, PharmD
Chief Pharmacy Officer
Outpatient Pharmacy

McBride Clinic Orthopedic Hospital

Booth # 719
Oklahoma City, OK
Timothy Anderson, RPh, MPH
Director of Pharmacy
Outpatient Pharmacy

McLeod Health

Booth # 500
Florence, SC
Charles Rozak, MS
Pharmacy Director
Outpatient Pharmacy

McLeod Regional Medical Center

Booth # 501
Florence, SC
Artie McKnight, RPh
Pharmacy Business Manager

MedAssets

Booth # 607
Leander, TX
Sam Colletti, RPh
Dir, Clinical Pharmacy - CHRISTUS Health

MedAssets

Booth # 608
Plano, TX
Ron Hartmann, PharmD
Senior VP, Pharmacy

MedAssets

Booth # 606
Plano, TX
Jimmy Loftin, RPh
VP, Pharmacy Contracting

Medical Center Arlington

Booth # 714
Arlington, TX
Darrell Newcomer, MS, FASHP
Director of Pharmacy

Medical Center of McKinney

Booth # 715
McKinney, TX
Fung Chang
Pharmacy Director

Medical Center of Trinity

Booth # 114
Trinity, FL
Ankit Patel
Director of Pharmacy Services

Medical University of South Carolina (MUSC)

Booth # 418
Charleston, SC
Donna Barrio, PharmD
Coordinator, Pharmacy Support Services

Medical University of South Carolina (MUSC)

Booth # 419
Charleston, SC
Dominic Ragucci, PharmD
Manager of Pediatric Pharmacy
Outpatient Pharmacy

MedStar National Rehabilitation Hospital

Booth # 1511
Washington, DC
Michael Roberts
Director of Pharmacy



PROVIDER ATTENDEES LIST BY FACILITY



Memorial Hospital Chattanooga

Booth # 403
Chattanooga, TN
Rodney Elliott
Pharmacy P.A./Technology/ Coordinator
Outpatient Pharmacy

Memorial Sloan Kettering Cancer Center

Booth # 1404
New York, NY
Stella Eng, RPh
Associate Director
Outpatient Pharmacy

Mercy El Reno, Kingfisher, Logan, Watonga Hospitals

Booth # 1104
Kingfisher, OK
Marette Forman, DPh
Mercy Regional Pharmacy Services Manager

Mercy Health System

Booth # 1100
Fort Scott, KS
Craig Campbell, RPh
Pharmacy System Performance Director
Outpatient Pharmacy

Mercy Hospital Ardmore

Booth # 1105
Ardmore, OK
Mark Glenn, PharmD
Director of Pharmacy

Mercy Hospital Oklahoma City

Booth # 1106
Oklahoma City, OK
Keith Madison, PharmD
Regional Executive Director of Pharmacy
Outpatient Pharmacy

Mercy Hospital Springfield

Booth # 1101
Springfield, MO
Daniel Good
Regional Exec Director Pharmacy Services

Methodist Charlton Medical Center

Booth # 700
Dallas, TX
Jeena Connor
Director of Pharmacy Services

Methodist Dallas Medical Center

Booth # 701
Dallas, TX
Jon Albrecht, RPh, MHA, BCNSP, FASHP
Director of Pharmacy

Methodist Health System

Booth # 702
Mansfield, TX
Velvette Dunn, PharmD, MPA
Director of Pharmacy Services

Methodist Jennie Edmundson Hospital

Booth # 1011
Council Bluffs, IA
Melanie Ryan, PharmD
Pharmacy Director

Methodist Olive Branch Hospital

Booth # 307
Olive Branch, MS
Ocpivia Stafford, Pharm.D., MBA
Pharmacy Director

Methodist Richardson Medical Center

Booth # 703
Richardson, TX
Jabeen John
Director of Pharmacy

Miami Children's Hospital

Booth # 118
Miami, FL
Irvin Alfonso, PharmD.
Director of Pharmacy

MidAmerica Division HCA, Parallon

Booth # 1015
Shawnee, KS
Joseph Burwinkle, BS, MS
Division Director of Pharmacy Operations

Ministry Health Care/Saint Michaels Hospital

Booth # 1115
Stevens Point, WI
Dave Groen
Pharmacy Director

Mission Health System

Booth # 414
Asheville, NC
Doug DeJong, RPh, MBA, FASHP
Executive Director of Pharmacy
Outpatient Pharmacy

Mission Health System

Booth # 415
Asheville, NC
John Randall, RPh, MBA
Director of Pharmacy Supply Chain

Mission Hospital Outpatient Infusion Center

Booth # 416
Asheville, NC
Diane Walter, PharmD
Pharmacy, Cancer/Infusion Svcs
Outpatient Pharmacy

Monterey Park Hospital, CA

Booth # 818
Monterey Park, CA
Van Anh Ngo
Director of Pharmacy

Morristown Medical Center

Booth # 1523
Morristown, NJ
Cliff Moore, RPh
Manager of Pharmacy
Outpatient Pharmacy

Mount Sinai Hospital, Chicago

Booth # 1218
Chicago, IL
Sameer Shah, PharmD, MHA
Director of Pharmacy
Outpatient Pharmacy

Mt. Sinai Medical Center Miami

Booth # 119
Miami Beach, FL
Mukesh Shah, RPh, MBA (HCM)
Director of Pharmacy
Outpatient Pharmacy

Nacogdoches Memorial Hospital

Booth # 706
Nacogdoches, TX
David Schaefer, MS, RPh
Director of Pharmacy
Outpatient Pharmacy

Nazareth Hospital

Booth # 1514
Philadelphia, PA
Richard Centafont
Director of Pharmacy

New York City Department of Health

Booth # 1319
Astoria, NY
Danielle Petrocelli, Pharm.D.
Executive Director of Pharmacy

New York City Department of Health

Booth # 1318
Astoria, NY
Rommel Babaan, Pharm.D.
Director of Pharmacy

North Kansas City Hospital

Booth # 1020
North Kansas City, MO
David Hitchcock
Pharmacy Operations Manager
Outpatient Pharmacy

North Mississippi Medical Center

Booth # 308
Tupelo, MS
Patti Hawkins, PharmD
Director-Outpatient Services
Outpatient Pharmacy

North Philadelphia Health System

Booth # 1316
Philadelphia, PA
Alan Stern, RPh MBA

**1 ONE UNIT
ONE DOSE
ONE AND ONLY**



HURRICAIN ONE®

Unit Dose Non-Aerosol Spray
20% Benzocaine Oral Anesthetic
0.5 mL each

ORIGINAL WILD CHERRY FLAVOR



An Innovative Non-Aerosol Unit Dose Topical Anesthetic Spray

- Meets Joint Commission Standard for the most ready-to-administer form available.*
- Fast onset. Short duration. Virtually no systemic absorption.
- Utilizes bar code medication administration (BCMA) to accommodate point-of-care scanning.
- Virtually eliminates adverse events resulting from preventable medication errors, ensuring the “5 Rights” are met:
 - ✓ Right Drug ✓ Right Patient ✓ Right Dose ✓ Right Route ✓ Right Time
- Single unit-of-use packaging eliminates the potential for cross-contamination.
- Increases billing accuracy and improves supply chain costs.

ORDERING INFORMATION

NDC#	AMERISOURCE BERGEN	CARDINAL HEALTH	MCKESSON	MORRIS & DICKSON	PRODUCT
0283-0610-11	10090081	CIN 4362547	1410125	086611	HurriCaine ONE® Unit Dose Non-Aerosol Spray Box of 2, 0.017 fl. oz. (0.5 mL) each
0283-0610-26	10090082	CIN 4363370	1411925	086629	HurriCaine ONE Unit Dose Non-Aerosol Spray Box of 25, 0.017 fl. oz. (0.5 mL) each

If HurriCaine ONE is not yet available through your wholesaler, request it by name and NDC Number.

*Joint Commission Standard: MM.05.01.11, EP4



MAKE THE SWITCH TODAY.

Call 1-800-238-8542 to place your order or request more information.
www.beutlich.com. HurriCaine ONE is a registered trademark of Beutlich® Pharmaceuticals, LLC. HCOA 650 1214

PROVIDER ATTENDEES LIST BY FACILITY



Corporate Director of Pharmacy Services
North Vista Hospital (Prime Healthcare)
Booth # 911
North Las Vegas, NV
Reggie Maynigo, Pharm.D.
Pharmacy Director

Northern Arizona Health
Booth # 601
Flagstaff, AZ
Richard Mendribil, PharmD
Health System Director of Pharmacy
Outpatient Pharmacy

Northridge Hospital Med Ctr
Booth # 819
Northridge, CA
Blair Galbreath, PharmD
Director of Pharmacy

Norwalk Hospital
Booth # 1509
Norwalk, CT
Robert Bepko, Jr., BS, Pharm., MHA
Admin Director Network Pharmacy Services
Outpatient Pharmacy

Novation
Booth # 717
Irving, TX
Brian Romig, BS, RPh, MBA
Vice President – Pharmacy

Novation
Booth # 716
Irving, TX
Leslie Larsen
Portfolio Executive

NYC Department of Hlth and Mental Hygiene
Booth # 1320
New York, NY
Eric Zimiles
Asst Commissioner of Admin & Operations

NYU Langone Medical Center
Booth # 1405
New York, NY
Arash Dabestani, PharmD, MHA, FASHP, FABC
Senior Director of Pharmacy
Outpatient Pharmacy

Oakwood Hospital and Medical Center
Booth # 1120
Dearborn, MI
David Batkie, RPh, MBA
Director of Pharmacy
Outpatient Pharmacy

Ocala Reg Med Ctr & West Marion Com Hosp
Booth # 113
Ocala, FL
Jerry Cummings
Director of Pharmacy

Ochsner Medical Center - New Orleans
Booth # 316
New Orleans, LA
Jason Chou, PharmD, MS
Director of Pharmacy

Oconee Memorial Hospital
Booth # 506
Seneca, SC
Bill Stevenson, BS Pharm
Pharmacy Manager

Orlando Regional Medical Center
Booth # 100
Orlando, FL
William Wilson
Pharmacy Manager

Oroville Hospital
Booth # 820
Oroville, CA
Daniel Nguyen, Pharm D
Director of Pharmacy

Overland Park Regional Medical Ctr (HCA)
Booth # 1014
Overland Park, KS
Cheryl Hurst
Director of Pharmacy

Parallon/HCA North Florida Division
Booth # 115
Jacksonville, FL
Michael Deschaine
Division Director of Pharmacy Operations

PDM Healthcare
Booth # 1216
Cleveland, OH
Ash Chawla
President/CEO

PDM Healthcare
Booth # 1217
Cleveland, OH
Tony Viridi
Director, Contracts/Sales Administration

PDM Healthcare
Booth # 1215
Cleveland, OH
Kimberly Arth

Penn State Milton S. Hershey Medical Center
Booth # 1314
Hershey, PA
Ronald Lay, MS, RPh, FASHP
Director of Pharmacy
Outpatient Pharmacy

Phelps County Regional Medical Center
Booth # 1111
Rolla, MO
Kreig Moore, RPh
Director of Pharmacy Services
Outpatient Pharmacy

Phoenixville Hospital
Booth # 1414
Phoenixville, PA
Lawrence Jones, RPh
Director of Pharmacy

Pikeville Medical Center
Booth # 408
Pikeville, KY
Roy Reasor
Pharmacy Manager
Outpatient Pharmacy

Premier Inc.
Booth # 413
Charlotte, NC
Angela Merryman, RPh, MS
Director, Pharmacy Contracting

Premier Inc.
Booth # 412
Charlotte, NC
Chris Jones, R.Ph
Director - Pharmacy Automation

Presence Saint Joseph Medical Center
Booth # 1301
Joliet, IL
Mark Deaton
Pharmacy Operations Manager

Prime Healthcare Management
Booth # 804
Ontario, CA
Christina Cao, Pharm.D
Corporate Manager for Pharmacy

ProHealth Care
Booth # 1116
Waukesha, WI
Virginia Mendoza
Director of Pharmacy Services
Outpatient Pharmacy

Providence Hospital
Booth # 213
Mobile, AL
Gino Agnelly
Director of Pharmacy

Rapid City Regional Hospital
Booth # 1002
Rapid City, SD
Dana Darger, RPh
Director of Pharmacy
Outpatient Pharmacy

PROVIDER ATTENDEES LIST BY FACILITY



Regional Medical Center

Booth # 507
Orangeburg, SC
Ann Ittenbach
Director of Pharmacy
Outpatient Pharmacy

Research Medical Center

Booth # 1108
Kansas City, MO
Robert Bub, PharmD
Director of Pharmacy

Resource Optimization & Innovation (ROi)

Booth # 1102
St Louis, MO
Leigh Lambert
Sourcing Manager - Pharmacy

Retreat Doctors' Hospital

Booth # 516
Richmond, VA
Jennifer Hill, PharmD
Pharmacy Director
Outpatient Pharmacy

Riverside Health System (RRMC)

Booth # 511
Newport News, VA
Lindsay Enzor
Director of Pharmacy
Outpatient Pharmacy

Riverside Health System (Williamsburg)

Booth # 512
Newport News, VA
Joshua Coffield
Director of Pharmacy
Outpatient Pharmacy

ROi

Booth # 1103
St. Louis, MO
Jill Webb
Senior Contract Manager - Pharmacy

RWJ University Hospital Somerset

Booth # 1524
Somerville, NJ
Stuart Vigdor, RPh
Director of Pharmacy

Saddleback Memorial Medical Center

Booth # 900
Laguna Hills, CA
Kathleen Cross, PharmD, MBA
Director of Pharmacy Services
Outpatient Pharmacy

Saint Agnes Hospital

Booth # 1518
Baltimore, MD
Greg Smith, RPh, MBA
Director of Pharmacy

Saint Francis Health System

Booth # 720
Tulsa, OK
Ron Kolar, DPh, MS, FASHP
System Director of Pharmacy Services

Saint Francis Healthcare

Booth # 1515
Wilmington, DE
Cheri Briggs, B.Pharm, PharmD, MBA
Director of Pharmacy

San Joaquin Community Hospital

Booth # 902
Bakersfield, CA
Adrian Gonzales, PharmD BCPS
Director of Pharmacy

SBH Health System

Booth # 1406
Bronx, NY
Ruth Cassidy, B.S. PharmD FACHE
Vice President of Clinical Services

SCL Health

Booth # 918
Lakewood, CO
Jennifer Davis, PharmD, MBA, BCPS, FASHP
Director of Pharmacy Services
Outpatient Pharmacy

Scottsdale Healthcare

Booth # 602
Scottsdale, AZ
Nancy Chang, PharmD, MHA
Pharmacy Director

Sentara Healthcare

Booth # 519
Norfolk, VA
Edwin Gutshall, PharmD
Pharmacy Business Manager

Seton Medical Center

Booth # 802
Daly City, CA
Martha Yasavolian
Director Pharmacy Services

Shore Medical Center Hospital

Booth # 1526
Somers Point, NJ
Matthew Piskun, PharmD
Director of Pharmacy

Shriners Hospitals for Children HQ

Booth # 120
Tampa, FL
Butch Parks, R.Ph., M.S.
Corporate Director of Pharmacy

Sierra View Medical Center

Booth # 903
Porterville, CA
Aaron Gates
DOP

Singing River Health System

Booth # 311
Pascagoula, MS
Madelline Collazo, PharmD
System Director of Pharmacy Services
Outpatient Pharmacy

Sisters of Providence Health System (SPHS)

Booth # 1504
Springfield, MA
Heather Upchurch, Pharm.D.
Pharmacy Director

South Georgia Medical Center

Booth # 302
Valdosta, GA
Cindy Vickery, RPh
Director of Pharmacy

South Lake Hospital (Orlando Health)

Booth # 101
Clermont, FL
Jeanette Bonstrom, RPh, CPh
Pharmacy Manager

Southern Hills Hospital-HCA

Booth # 908
Las Vegas, NV
Daniel Kim, RPh
Director of Pharmacy Services

Southwestern Medical Center

Booth # 800
Lawton, OK
Robin Garmon
Director of Pharmacy

Sparrow Healthcare System

Booth # 1200
Dewitt, MI
Carol Welch, Pharm D MS
Medication Safety Officer
Outpatient Pharmacy

Spartanburg Medical Center

Booth # 508
Spartanburg, SC
Brian Nesemeier, Pharm
Manager Pharmacy
Outpatient Pharmacy

Spring Valley Hospital Medical Center

Booth # 914
Las Vegas, NV
Brian Cruz, PharmD
Assistant Director





Learn how hospitals
across the country are
**SAVING ON THEIR
UNIT-DOSE DRUG
COSTS** by using
Safecor Health's
packaging services

Working with over 1,000 individual hospitals,
multi-site & multi-state health systems.
Services are on contract with your GPO.

SAFECOR **R**
HEALTH

800.447.1006

www.safecorhealth.com

PROVIDER ATTENDEES LIST BY FACILITY

**St. Bernards Medical Center**

Booth # 400
Jonesboro, AR
Wendy Jordan
Pharmacy Manager

St. Christopher's Hospital for Children

Booth # 1315
Philadelphia, PA
Loan Vu, PharmD, MBA
Director of Pharmacy Services

St. Dominic Hospital

Booth # 312
Jackson, MS
Mary Helen Bowen, RPh
Assistant VP, Pharmacy Services
Outpatient Pharmacy

St Elizabeth & Our Lady of the Angels Hospital

Booth # 317
Gonzales, LA
Tammy Belleau, RPh
Senior Director of Pharmacy

St. Francis Hospital

Booth # 404
Memphis, TN
Marilyn Jackson, Pharm.D., MBA
Director of Pharmacy

St. Francis Hospital, Inc.

Booth # 303
Columbus, GA
John Drew, III, PharmD
DOP

St. John Hospital & Medical Ctr (Ascension)

Booth # 1201
Detroit, MI
Kevin Dubay
Mgr, Operations Dept of Pharmacy Svcs

St. John Medical Center

Booth # 801
Tulsa, OK
Fred Keehn
Director of Pharmacy

St. Jude Children's Research

Booth # 405
Memphis, TN
Bruce Warren
Director of Pharmacy
Outpatient Pharmacy

St Louise Regional/O'Connor Hospital

Booth # 803
San Jose, CA
Norm Fox, Pharm. D., MS
Pharmacy Director Santa Clara Market

St Lukes Hospital at The Vintage

Booth # 707
Houston, TX
Jerry King, RPh, MBA
Director of Pharmacy

St. Mary - Corwin Medical Center

Booth # 919
Pueblo, CO
Ronnie Sullivan, RPh, PharmD
Director of Pharmacy
Outpatient Pharmacy

St. Mary's Health Care System

Booth # 304
Athens, GA
Gary Wright, RPh
Pharmacy Director

St. Mary's Hospital

Booth # 1302
Centralia, IL
Monica Heinzmann, Pharm.D.
Director of Pharmacy

St. Vincent Carmel Hospital

Booth # 1202
Carmel, IN
Michael Mendenhall
Pharmacy Director

St. Vincent Hospital and Healthcare System

Booth # 1203
Indianapolis, IN
Anthony Antonopoulos, RPh, MBA
Executive Director, Regional Pharmacy Svcs

St. Vincent Women's Hospital

Booth # 1204
Indianapolis, IN
Lori Skwarcian
Pharmacy Director

Stormont-Vail HealthCare

Booth # 1012
Topeka, KS
Kevin Waite, PharmD
Director of Pharmacy
Outpatient Pharmacy

Summerlin Hospital Medical Center

Booth # 915
Las Vegas, NV
Steve McMillan
Director of Pharmacy

SUNY Downstate Medical Center

Booth # 1407
Brooklyn, NY
LilyAnn Jeu
Clinical Manager/Medication Safety Officer

Swedish American Hospital

Booth # 1303
Rockford, IL
Thomas Carey, PharmD
Director of Pharmacy Services
Outpatient Pharmacy

Texas Health Huguley (Adventist Health)

Booth # 705
Burleson, TX
James Hall, RPH
Director of Pharmacy

Texas Health Presbyterian Hospital

Booth # 708
Flower Mound, TX
Todd Connor
Director of Pharmacy

The Center for Hematology-Oncology

Booth # 200
Boca Raton, FL
Sigal Nadulek, RPh, CPh
Pharmacy Manager

Thomas Hospital

Booth # 214
Fairhope, AL
Jennifer Broome, Pharm.D.
Pharmacy Manager
Outpatient Pharmacy

Trinity Mother Frances Hospitals & Clinics

Booth # 711
Tyler, TX
Wyley McCoy, PharmD, MBA
Director of Pharmacy
Outpatient Pharmacy

UF Health Cancer Center Orlando Health

Booth # 102
Orlando, FL
Andrea Ledford, PharmD, BCOP
Oncology Pharmacy Manager
Outpatient Pharmacy

Union Hospital of Cecil County

Booth # 1519
Elkton, MD
David Jaspan, BS. Pharm, MBA
Director, Pharmacy and Materials Management

United Regional Health Care System

Booth # 712
Wichita Falls, TX
Matt Baker, PharmD. BCPS
Director of Pharmacy

University of California San Diego Health

Booth # 904
San Diego, CA
Charles Daniels
Pharmacist-In-Chief



PROVIDER ATTENDEES LIST BY FACILITY



University of Illinois Hospital

Booth # 1304

Chicago, IL
Andrew Donnelly
Director of Pharmacy
Outpatient Pharmacy

University of Mississippi Medical Center

Booth # 313

Jackson, MS
Michael Todaro, PharmD
Director of Pharmacy
Outpatient Pharmacy

Upstate University Hospital

Downtown Campus

Booth # 1408

Syracuse, NY
Luke Probst, PharmD, BCPS
Director of Pharmacy

Vail Valley Medical Center

Booth # 920

Vail, CO
Terry Kermoade
Inpatient Pharmacy Manager

Valley Children's Hospital

Booth # 905

Madera, CA
Richard Sakai, PharmD, FASHP, FCSHP
Director of Pharmacy

Vaughan Regional Medical Center (Lifepoint)

Booth # 215

Selma, AL
Dalton Williamson

Director of Pharmacy

Virginia Hospital Center

Booth # 520

Arlington, VA
Dana Anderson
Director of Pharmacy

Waccamaw Community Hospital

Booth # 503

Murrells Inlet, SC
Darrell Willm, RPh
Director of Pharmacy

Wake Forest Baptist Health

Booth # 417

Winston-Salem, NC
Nate Peaty
Assistant Director, Quality Sys & Innovation

WellStar Health System

Booth # 305

Marietta, GA
Melissa Rippetoe, Pharm D.
Pharmacy Operations Manager
Outpatient Pharmacy

Western Arizona Regional Medical Center

Booth # 604

Bullhead City, AZ
Se Choi, PharmD
Director of Pharmacy Services

Wheaton Franciscan Saint Joseph

Booth # 1117

Glendale, WI
Christopher Dykstra
Pharmacy Operations Manager
Outpatient Pharmacy

White Plains Hospital Center

Booth # 1409

White Plains, NY
Patricia Byrne
Director of Pharmacy

Whitesburg ARH Hospital

Booth # 411

Whitesburg, KY
Michael Dick
Director of Pharmacy
Outpatient Pharmacy

Winthrop University Hospital

Booth # 1410

Mineola, NY
Brian Malone, BS, MS, RPh
Director of Pharmacy

Yavapai Regional Medical Center

Booth # 605

Prescott, AZ
Jeff Anderson, Pharm.D., M.S., BCPS
Director of Pharmacy Services

Zucker Hillside Hospital

Booth # 1411

Glen Oaks, NY
Anthony Longo, PharmD
Director, Pharmacy & Clinical Services



STOP BY OUR REGISTRATION DESK TO REGISTER FOR L.A.!

SPECIAL THANKS TO OUR
TITLE SPONSOR



CardinalHealth

Essential to care™

What's most important to your pharmacy?



With Cardinal Health Remote Pharmacy Services, you can have it all.

Learn how:

cardinalhealth.com/remotepharmacyservices

Cost savings

Experience 20 to 30 percent savings **over** the cost of hiring overnight staff

Patient safety

We intervene on medication orders three to five percent of the time — **half** of which are potential safety issues

24/7 Pharmacy coverage

Average turn-around time on orders less than 20 minutes



CardinalHealth

Essential to care™